

aspect 

Project
Specification
Sheet.

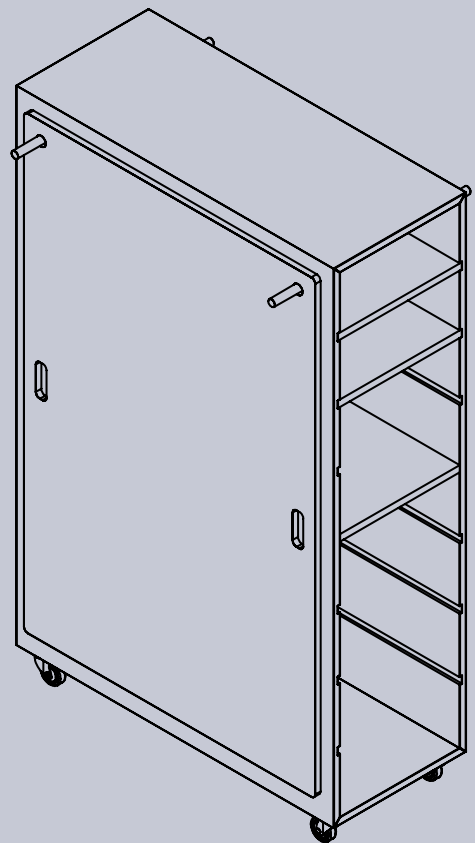



The Project series is functional, modular and ready to move.

This range facilitates a new way of working, helping people visualize their thinking and create collaboratively.

We know space is in high demand. With the Project series, we have thought about the details so you can think about what matters.

The robust and considered design of the Project series ensures maximum functionality within any space.



The Project series caters to a variety of needs, allowing you to assemble and reassemble the perfect thinking environment.

Features include:

- Easily movable units on industrial strength wheels
- A peg and board system that quickly multiplies wall space
- High quality materials
- New Zealand based design and manufacture
- Fast, easy assembly
- Minimal health and safety concerns with light-weight materials for the boards



Project series components are built to last, and will withstand repeated assembly and countless moves.



All units within the Project series are modular, designed to fit together seamlessly.

Other features for these units include smart storage space solutions, as well as plug-and-play points. Power and USB charging points can be added to units, making it easy to connect technology such as video-conferencing equipment.



The versatility of Project series allows for multiple possibilities in transforming workspaces.



The unique, cross-laminated cardboard construction of the boards creates a highly durable, yet lightweight product —effortless to move and with minimal health and safety concerns.

These boards can be displayed either on the movable storage wall, or mounted side by side to maximize wall space, using the Project board and peg system.

All Project series products pair well with a wide variety of accessories available from Aspect to further increase the utility of the range.



Aspect Design.



As furniture designers, our user-centric approach places people at the heart of every decision we make.

Applying 40+ years' of experience and craftsmanship, we create furniture to inspire and support people in their work every day. Manufacturing locally, and with full in-house design capability, we collaborate with interior designers, architects and clients to tailor-make environments.

We're here to support you in creating workplaces that encourage productivity, creativity and collaboration. High-performing spaces where high-performing people are empowered to do their best work.

Product specifications.

An Aspect product.
A design collaboration with Refold.
Made in New Zealand.

Laminate finishes



Snowdrift



Warm White



Rock Salt



Affinity Maple



Seal Grey



Storm



Raw Birch Ply



Rural Oak



Black



Blackened Legno



Refined Oak



Hamptons Elm

Custom finishes available on request

Board finishes

Along with cardboard and whiteboard finishes, an Autex Cube™ finish provides pin-board and acoustic features



Cardboard



Whiteboard
(single/double-sided)



Autex Cube™
(Full colour range available)

Sub-frame finishes



Mannex Appliance White



Mannex Black

Product specifications.

Peg finishes



Wood



White



Black

Range

- Project boards
- Project pegs
- Project mobile divider
- Project movable storage wall
- Project table
- Project table cluster
- Project movable TV unit
- Project movable kitchen unit

Warranty

10-Year warranty for normal commercial use

Lead time

6 weeks

Product range.

Project boards.



Available with cardboard, whiteboard or Autex Cube™ finishes.

Whiteboards should be wiped with a damp or dry cloth only. Chemicals should not be used on the surface.

Project pegs.



Mountable directly onto walls or indirectly via a rail. Spaced to suit Project board dimensions.

Multiple finishes available.

Product range.

Project mobile divider.



Includes:

- Project pegs

Project movable storage wall.



Includes:

- 6x movable shelves
- 1x fixed middle shelf

Product range.

Project table.



Project table cluster.



Consists of 2x Project tables.

Product range.

Project movable TV unit.



Includes:

- 5x reconfigurable shelves
- 1x 240v power bank
- Hidden cable space

TV and mounting bracket not included, but can be installed if requested.

Project movable kitchen.



Two options available.

Option 1 includes:

- 6x reconfigurable shelves
- 3x storage drawers

Option 2 includes:

- 3x 369mm wide slots, allowing space for rubbish and recycling bins.

Product specifications.

Project boards.

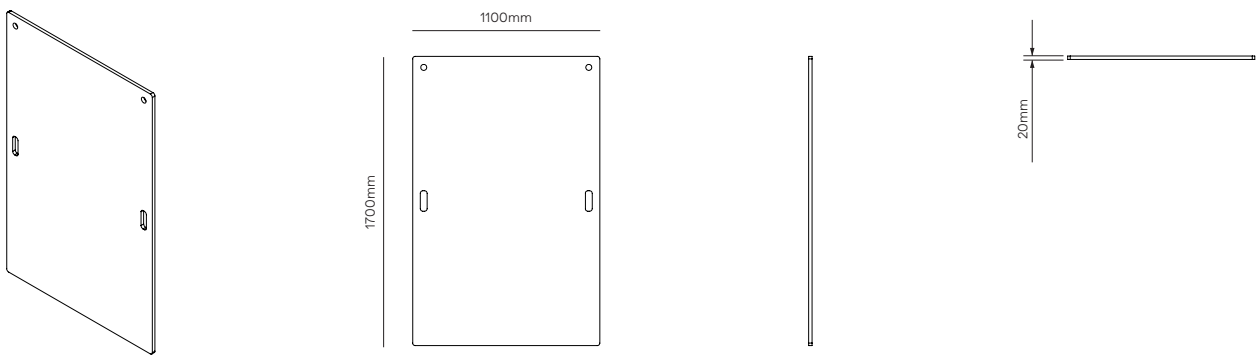

Product specifications.

Project mobile divider.

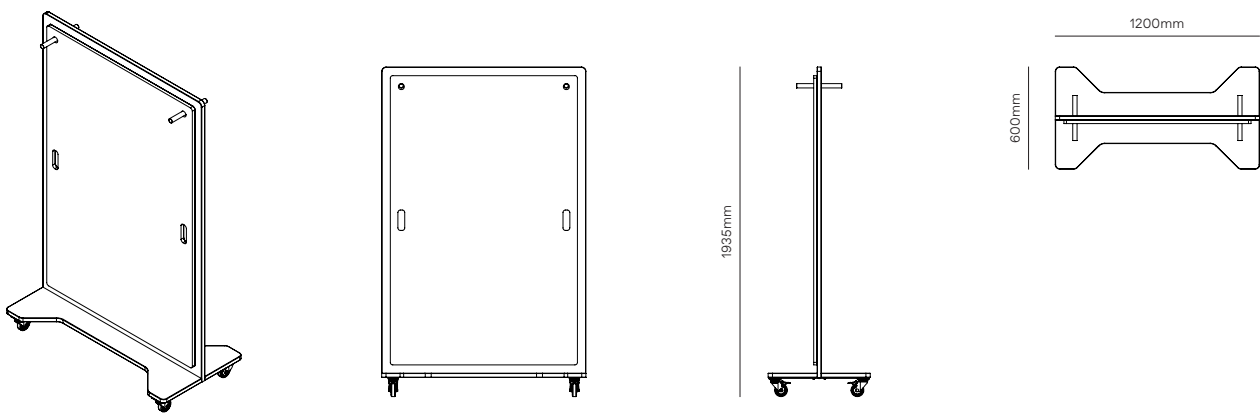

Project movable storage wall.

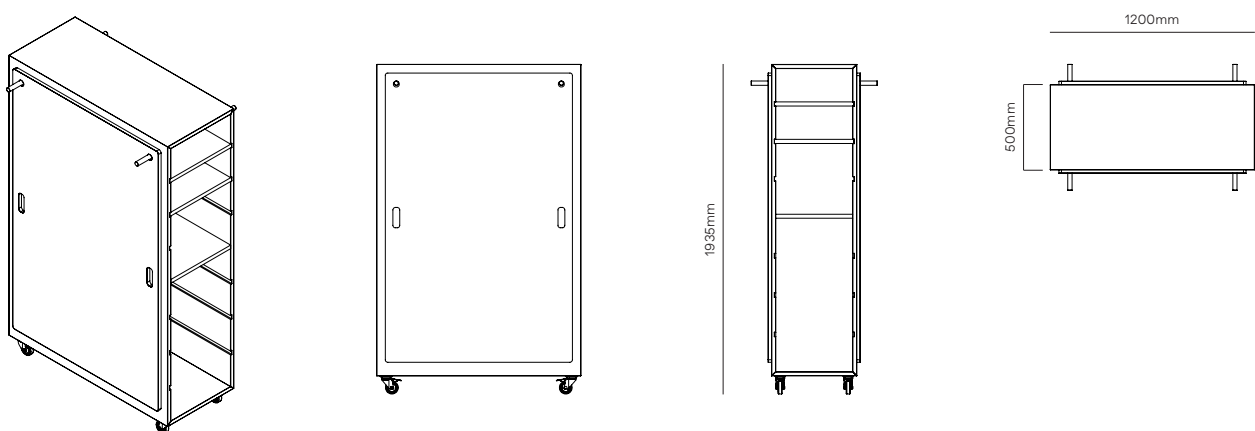

Product specifications.

Project table.

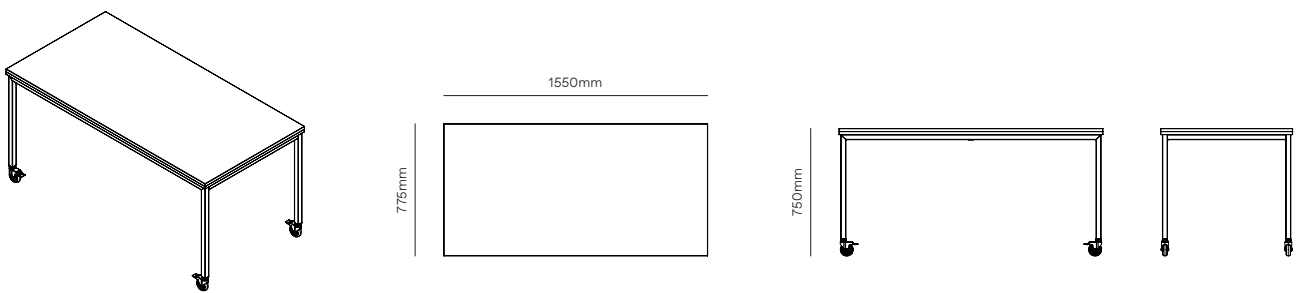

Project movable storage wall.

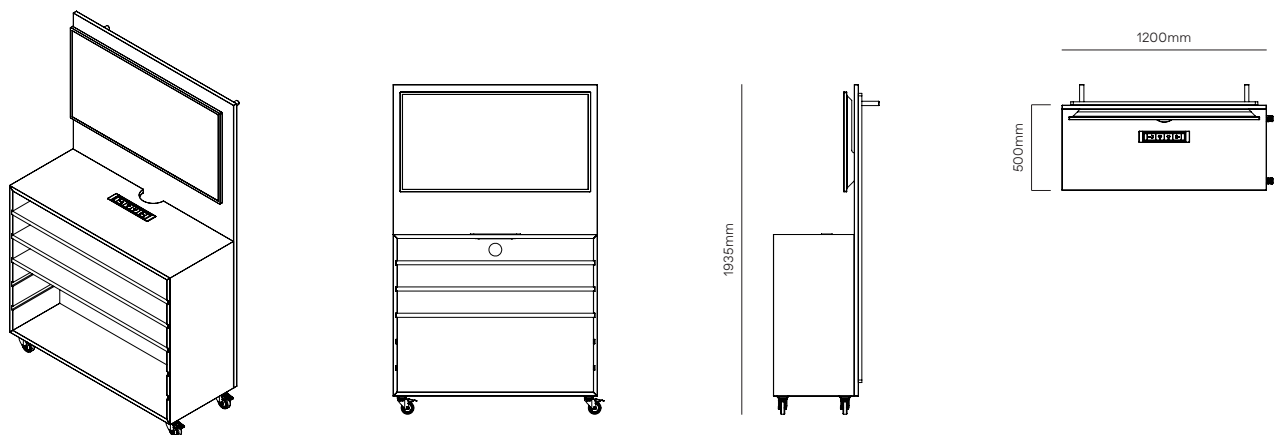

Product specifications.

Project movable kitchen - Unit 1.

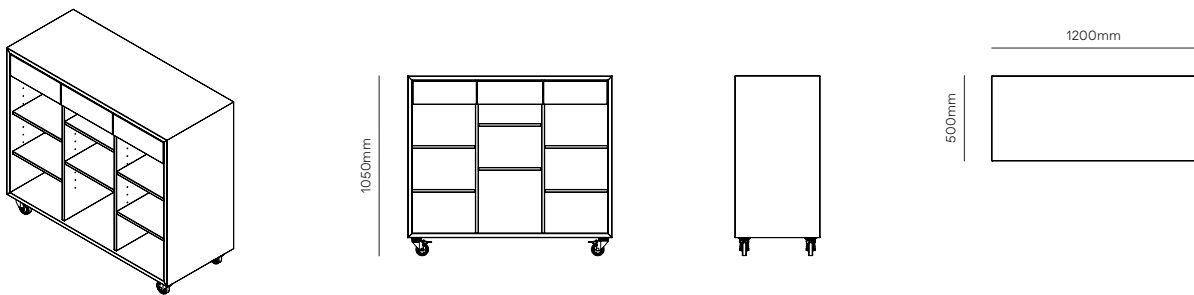

Project movable kitchen - Unit 2.

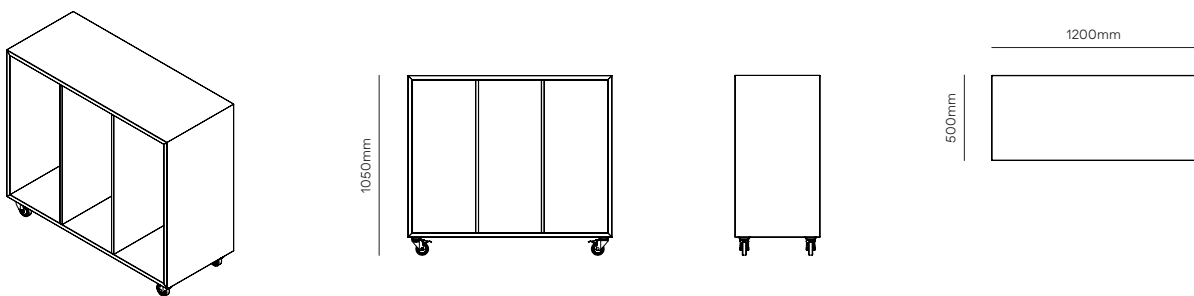



We are creative problem solvers that champion original thinking. We love sharing ideas, taking something and making it better together.

Please get in touch with us, we'd love to discuss your project.

New Zealand
0800 323 220
info@aspectfurniture.com

Australia
1800 696 334
infoau@aspectfurniture.com

aspectfurniture.com