

# M/Connect<sup>TM</sup> 2

USER GUIDE

## **Table of Contents**

PARTS REQUIRED	3
IDENTIFYING COMPONENTS	4
INSTALLING M/CONNECT BASE	6
ATTACHING A MONITOR ARM	9
ELECTRICAL SPECIFICATIONS	14

# PARTS REQUIRED

---

## M/Connect Parts

- A (1) M/Connect Hub and Dock
- B (1) Power Adaptor
- C (1) Power Cable (localized)
- D (1) USB-C Upstream Cable with USB-A adapter
- E (1) Upstream Cable Retainer

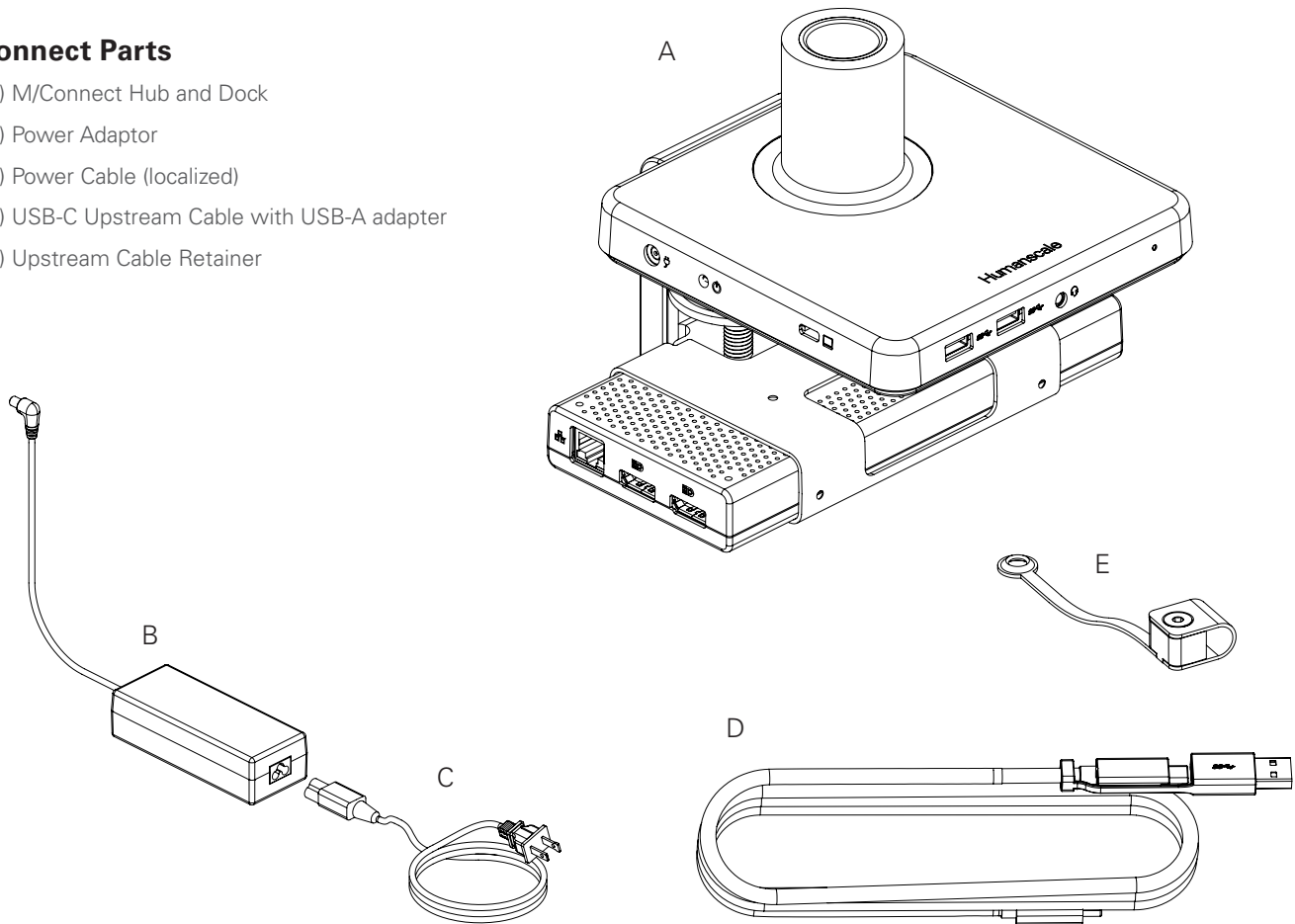

# INSTALLATION GUIDELINES

---

**This product is intended to be used with Humanscale’s Monitor Arm product line and the following office desk styles placed on a non-skid surface:**

1. Systems Furniture with panel hung surfaces
2. Systems Furniture with a floor mounted panel behind the desk
3. Systems Furniture with a desk mounted panel in the rear of the desk
4. Back-to-back desks sharing the same frame

**When mounting monitor arm and monitor(s) with this product on a freestanding desk/table:**

1. The freestanding desk/table should have base that is no less than 30” deep and 66.5” wide
2. The freestanding desk/table should be a minimum of 200 lbs and placed on a non-skid surface.
3. The tabletop thickness should be no less than 1.2 inches and strong enough to support a minimum weight load of 165lb.



**CAUTION: DO NOT** rotate monitor past rear edge of desk. Doing so can create an unstable situation and may cause equipment damage or personal injury.

# IDENTIFYING COMPONENTS

---

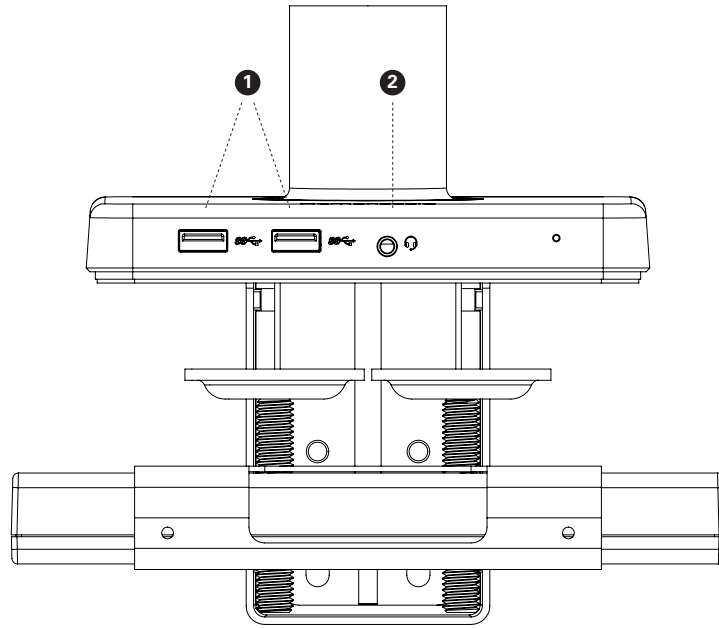

Front Panel

Component	Description
1 USB A port	Supports USB 3.1 Gen 1
2 USB A port	Supports USB 3.1 Gen 1
3.5 mm TRRS jack	To connect combined headphone and microphone headset

# IDENTIFYING COMPONENTS

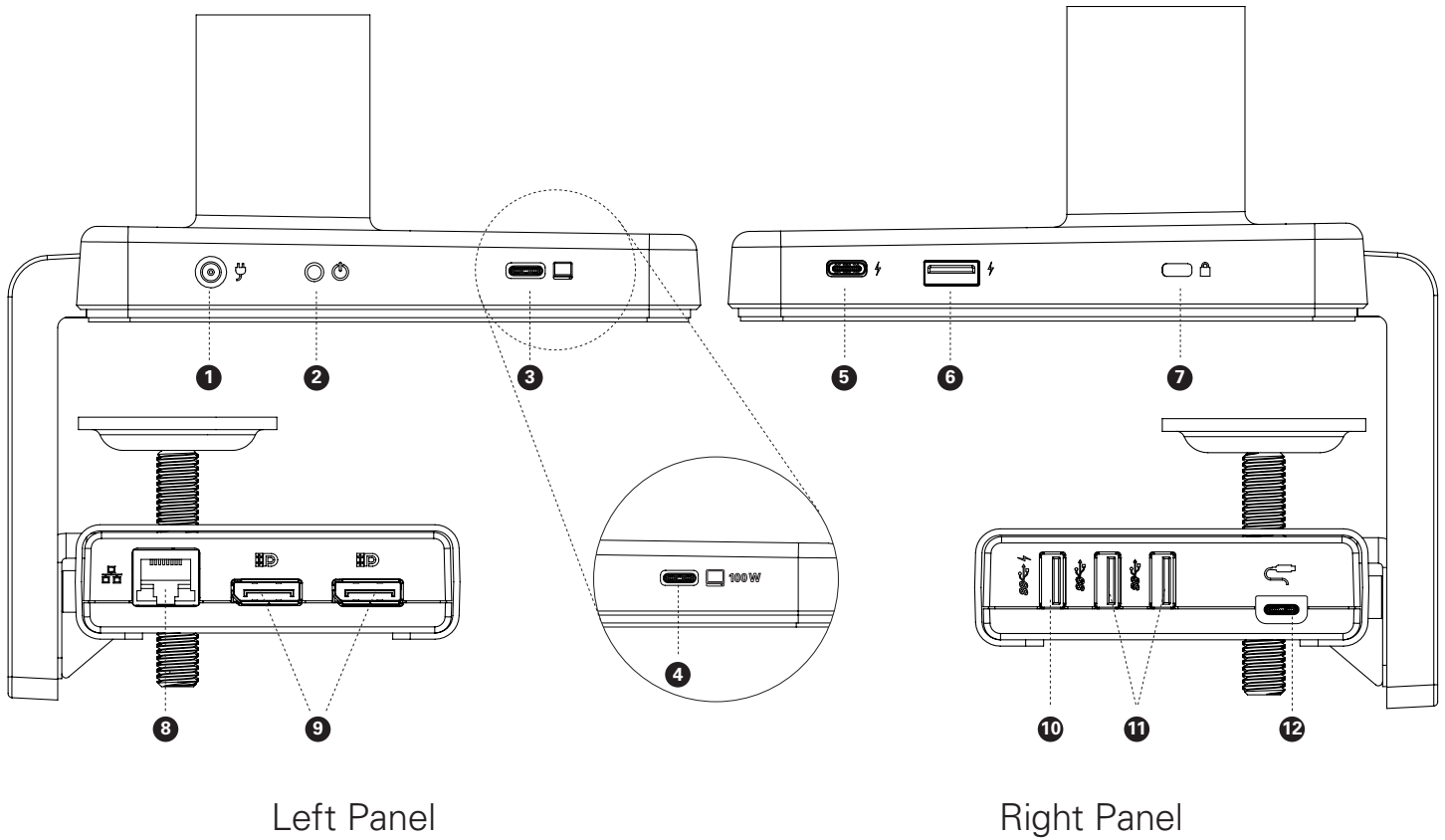

Left Panel

Right Panel

Component	Description
1 DC in	DC to M/Connect
2 Power Button	Powers unit on and off
3 USB-C Upstream Port (60W version)	Connects full featured USB-C cable to laptop, Supports PD charging at 60W max. <b>Important: only use USB-C cable provided with unit, other cables may void product warranty</b>
4 USB-C Upstream Port (100W version)	Connects full featured USB-C cable to laptop, Supports PD charging at 100W max. <b>Important: only use USB-C cable provided with unit, other cables may void product warranty</b>
5 USB-C Charging Port	Charges USB-C devices 5V, 3Amax
6 USB-A Charging Port	Charges USB-A devices 5V, 2.4A max
7 Kensington Slot	To secure unit from theft
8 Ethernet	To connect network to M/Connect
9 DisplayPort (2)	Connects to DisplayPort of monitor
10 USB-A Port	USB 3.1 Gen1, Supports charging 5V, 2.4A
11 USB-A Port (2)	USB 3.1 Gen1
12 USB-C Bridge Port	Connects cable supplied from the top hub; flat cable plug face has to face upward when plugging

# INSTALLING M/CONNECT SOFTWARE

## STEP 1

---

### **M/Connect Driver Installation Instructions**

YOU MUST INSTALL THE NECESSARY DRIVERS ONTO YOUR COMPUTER BEFORE USING M/CONNECT. THIS WILL ENSURE PROPER OPERATION.

NOTE: For proper installation of the DisplayLink drivers, it is important to make sure your USB 3.0 Host Controller Driver and Graphics Adapter Driver are up to date

- Go to <http://www.displaylink.com/downloads/>
- Choose your operating system
- Download and install the latest driver
- Ready to go!

## TROUBLESHOOTING

We recommend following these guidelines as a best practice.

### **Ensure installation isn't blocked by a corporate firewall**

If your firewall blocks the installation of this driver, corporate users should contact their systems administrator and have them allow this driver under their corporate installation standard procedures (MSI Installer), available for download from DisplayLink's website.

Individual users should ensure that suggestions to update other drivers are followed. This typically includes updating the laptop graphics and USB drivers to the latest version.

Updating the host graphics drivers to the latest version: For Windows 7, USB laptop drivers are provided by Intel/OEM notebook vendors. Users have to update this manually. Please refer to <http://support.displaylink.com> for more details. For Windows 8 onwards, laptop drivers are provided by Microsoft and updated in the system via Windows update.

**For the best user experience, we recommend running the latest version of the driver.**

# INSTALLING M/CONNECT ONTO EDGE OF TABLE

Caution: Maximum weightload of M/Connect is as follows: M2.1: 15.5 lbs. M8.1: 28 lbs. M10: 40 lbs. M/Flex: 60 lbs. Total.

M10 is not to be used on M/Flex when mounted to MConnect2

Do NOT exceed maximum weight limits.

When used in conjunction with M/Connect 2, M/Flex post must be limited to 24 inches

## OPTIONAL: INSTALL USB-C CABLE RETAINING CLIP

### Turn M/Connect upside down to access screw hole

- Screw cable retaining clip into sheet metal base

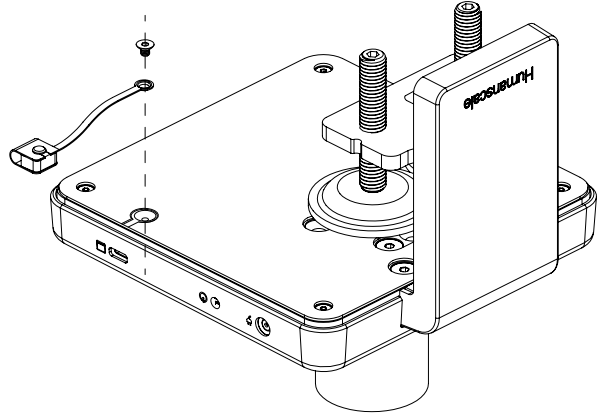

## STEP 1

### Place M/Connect Clamp onto Table

- Slide mount against work surface edge and fully tighten clamp screw (fig. A)

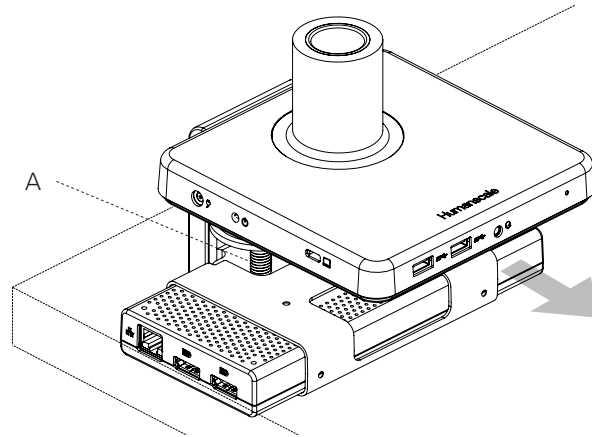

# INSTALLING M/CONNECT THROUGH A GROMMET HOLE OR SYSTEM FURNITURE

## STEP 1

### Disassemble Clamp

- Remove the two screws (fig. B) using hex key (fig. D) and detach the smaller clamp bracket (fig. C) from the larger bracket

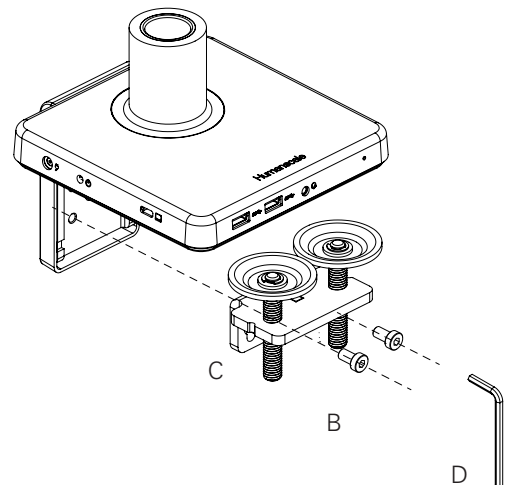

## STEP 2

---

### Place into Grommet Hole or System Furniture Gap

- Place the L Bracket of the M/Connect through the grommet hole and to the desired position

Note: Minimum hole diameter is 3" (76 mm)

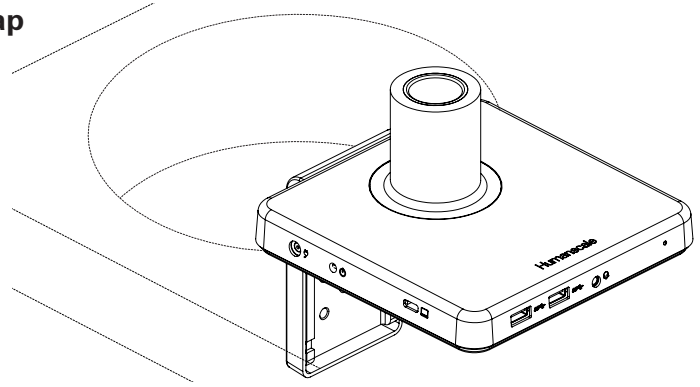

## STEP 3

---

### Reattach Clamps

- Secure the lower bracket to the larger bracket reusing the two screws

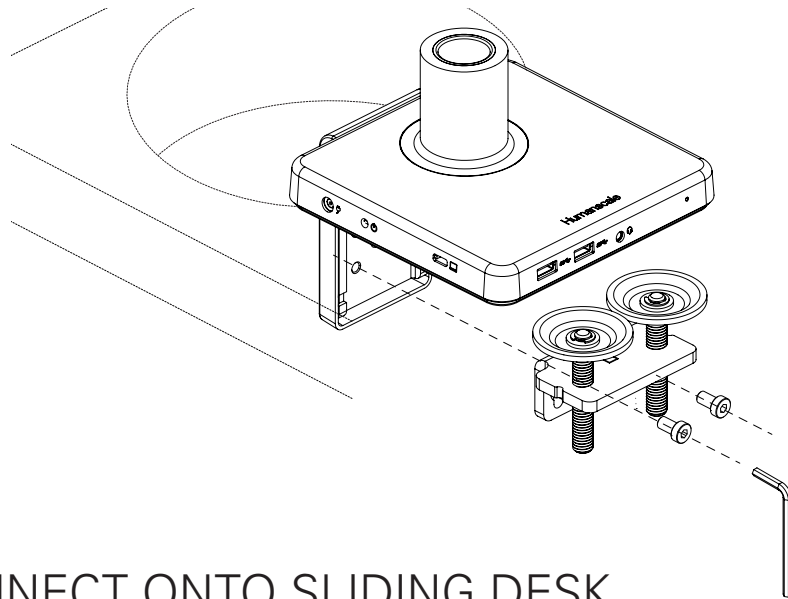

## INSTALLING M/CONNECT ONTO SLIDING DESK

### STEP 1

---

#### Remove Screws

- Remove clamp screws

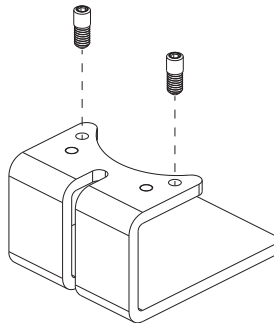



## STEP 2

---

### Install Sliding Desk Clamp

- Insert clamp into M/Connect, ensuring that the bridge cable passes unobstructed on the right side of the clamp
- Loosely install clamp screws

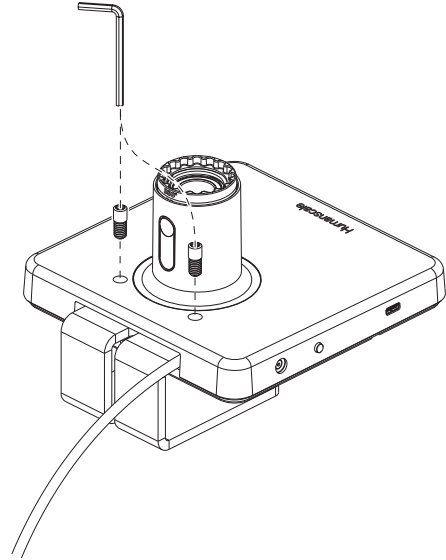
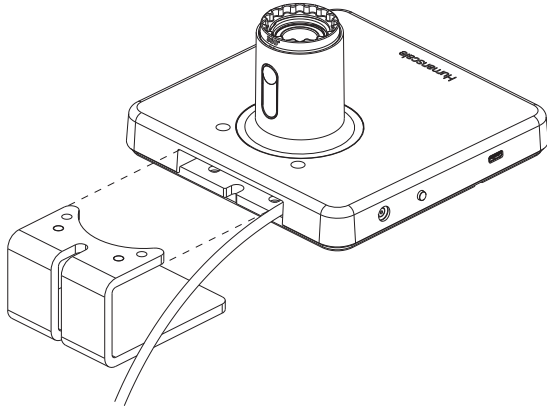

## STEP 3

---

### Attach M/Connect onto table edge

- Slide unit with loosely mounted bracket against work surface edge
- Tighten both set screws evenly into bracket to a snug fit (fig. E)

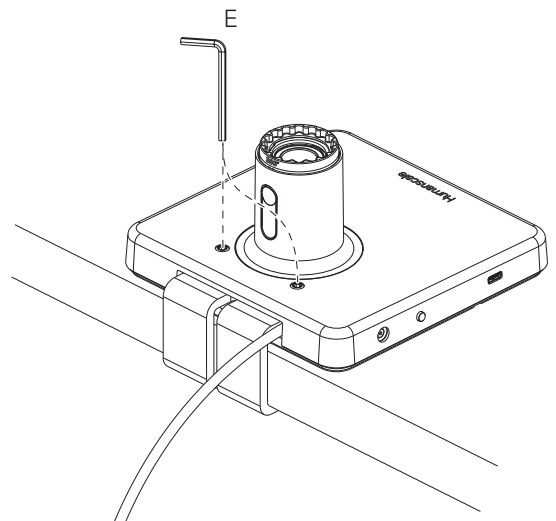
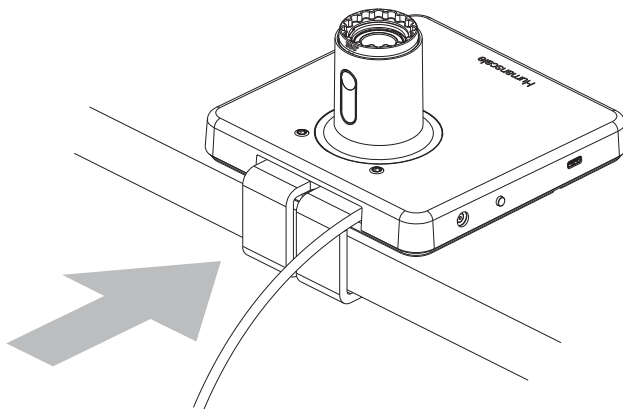

# ATTACHING AND REMOVING DOCK

- To attach dock, slide onto the clamp bracket (fig. F) until it snaps in place
- To remove dock, pull away from clamp while applying a downward force near front (Fig. G)
- Insert USB-C cable head from hub into dock, ensuring the plug orientation matches the socket (fig. H)
- The cable must be fully inserted for the unit to function (Fig. I)

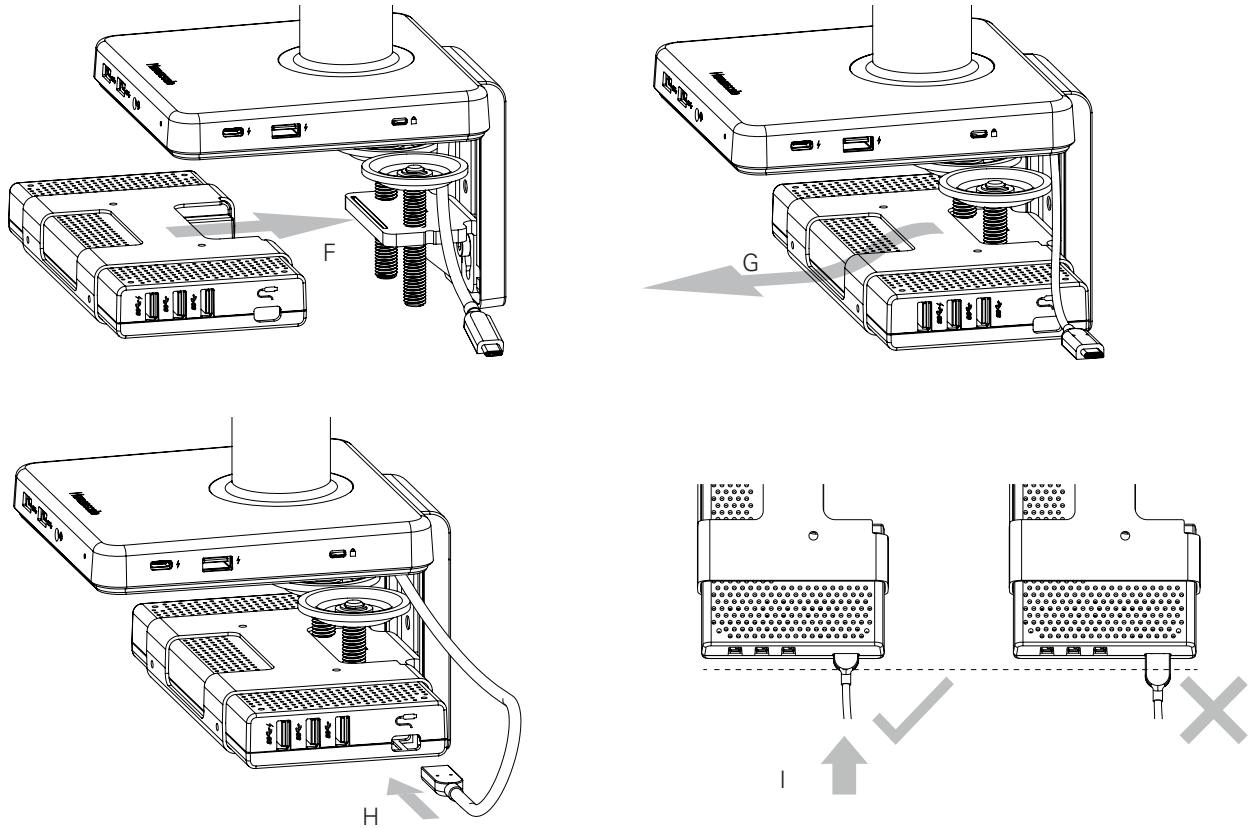

# ATTACHING A MONITOR ARM TO M/CONNECT

## M2.1/M8.1/M10 MONITOR ARM

### Insert Arm into M/Connect Base

- Refer to monitor arm instructions to setup smart stop ring
- Insert Monitor Arm into the Base stem (fig. K) until it clicks into place
- Refer to monitor arm instructions to continue installation

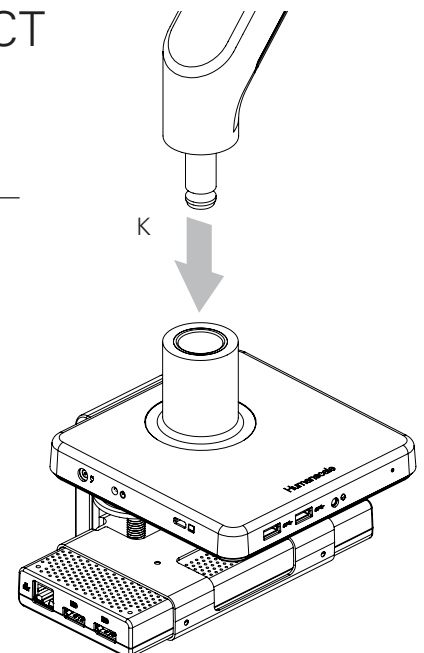

# ATTACHING A MONITOR ARM TO M/CONNECT

## M/FLEX MONITOR ARM

### Insert M/Flex Post into M/Connect Base

- Back out the two set screws installed in stem (fig. L)
- Insert M/Flex post (fig. M) into Base and twist onto internal bolt until fully seated
- Tighten both set screws evenly (fig. L) to secure post using hex key

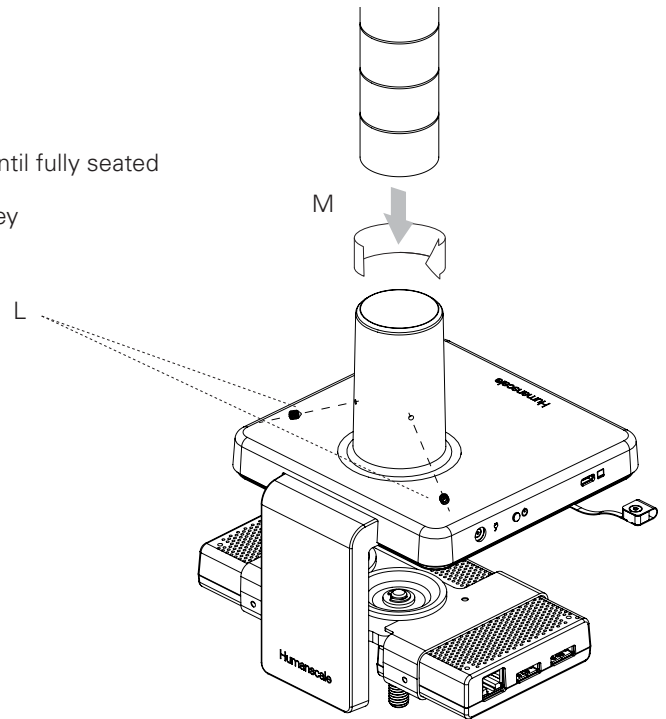

## BOLT-THROUGH MOUNT

### Installing on a work surface with no clamp system

- Drill half inch hole in desired location
- To ensure M/Connect makes full contact with desk, locate hole at least two inches from back edge of desk
- Lower M/Connect onto desk aligning bolt with hole
- Slide the bolt-through plate (fig. I) over the bolt and tighten the nut , ensuring a secure fit
- Place the protective plastic cap onto bottom of the bolt (fig. J)

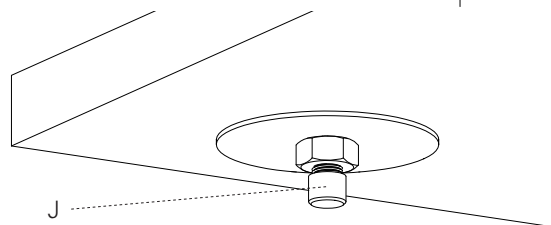
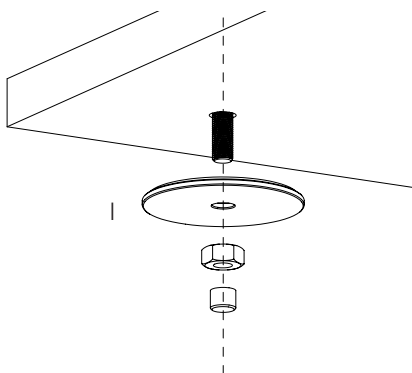
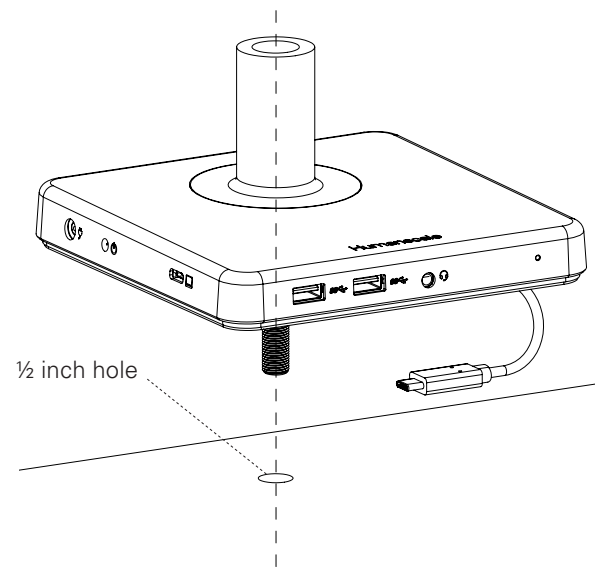

# CONNECTING CABLES TO M/CONNECT

## Plug in power cable

- Insert power cable (fig. N) into rearward power jack
- LED light (fig. O) will illuminate to indicate power

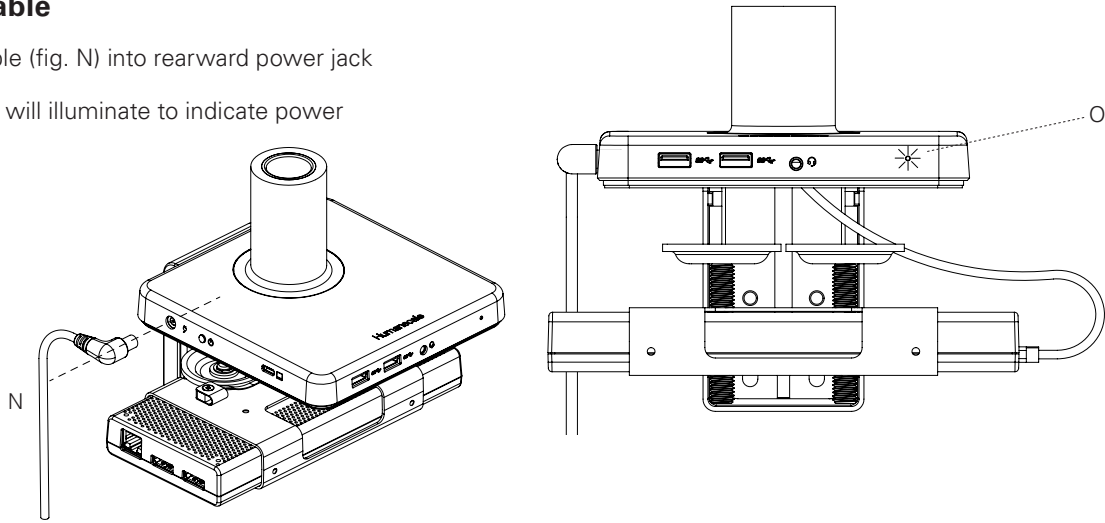

**CAUTION:** The 60W M/Connect 2 requires the 150W power supply. The 100W M/Connect 2 requires the 180W power supply. Attaching the 150W power supply to the 100W M/Connect 2 will cause the unit to turn off.

## Connect upstream cable from source to hub

- Remove screw (fig. P) from cable retaining clip
- Remove plastic insert (fig. Q) from retaining clip and insert USB-C upstream cable
- Snap plastic insert back into retaining clip and secure with screw

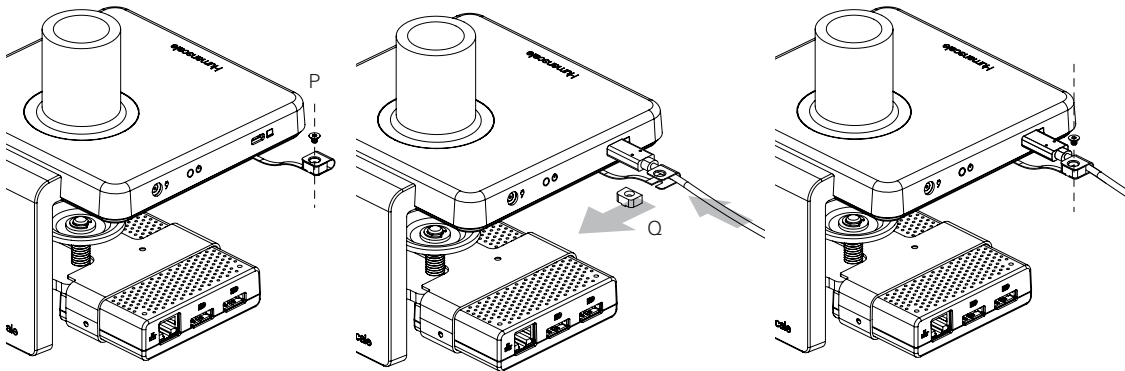

- When attaching USB - A-to-C adapter, make sure to properly align connector head with adapter upon insertion

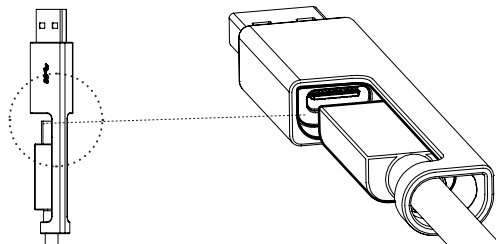

# MOUNTING THE M/CONNECT DOCK

## Horizontal Alignment

- Screw bracket (fig. R) into desk underside and slide dock in
- Attach screw. (fig. S) through bracket into dock to fully secure

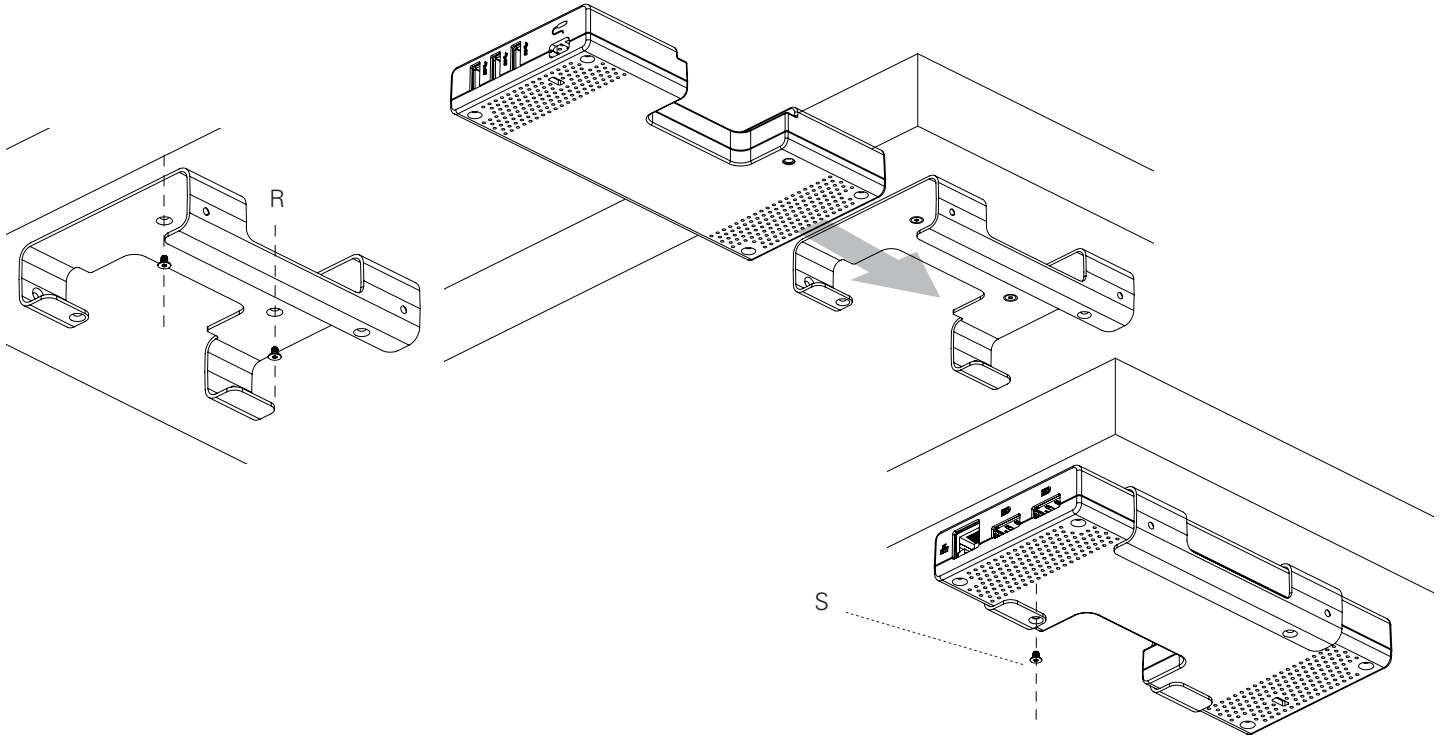

## Vertical Alignment

- Screw bracket (fig. T) into desk underside and slide dock in
- Attach screw. (fig. U) through bracket into dock

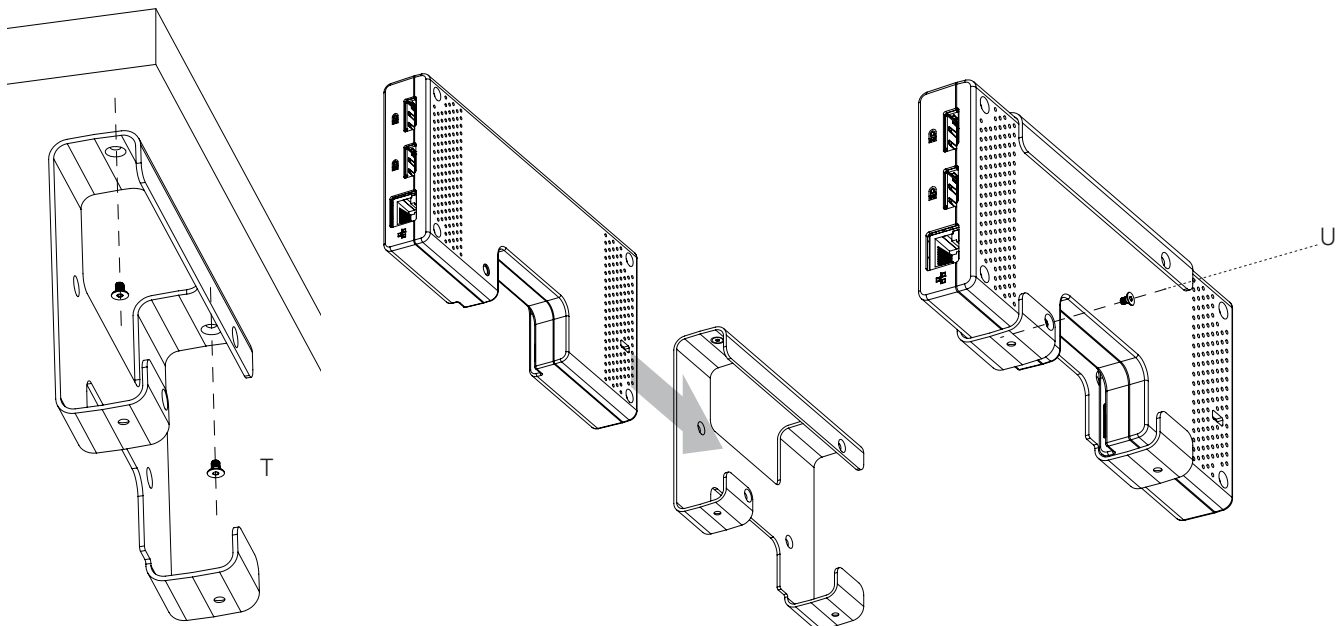

# SECURING THE DOCK

## Using a K-Lock into dock

- Use K-Slot opening on dock to attach K-Lock device (fig.V)

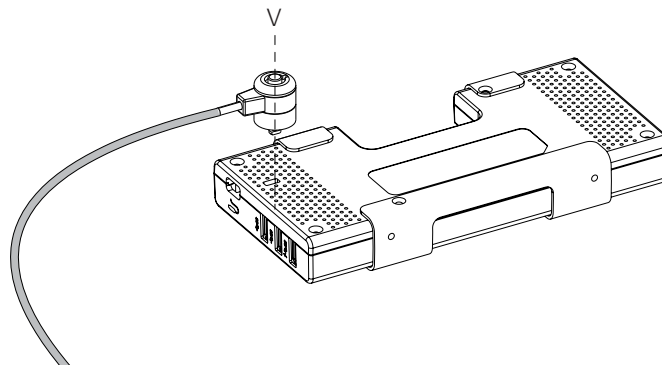

## Using a K-Lock cable pass-through dock

- To secure with cable pass through, orient dock bracket to enclose gap (fig. W)
- Pass lock cable through gap in dock and loop around table leg or fixed object (fig. X)
- Fasten K-Lock to M/Connect hub (fig. Y) to fully secure

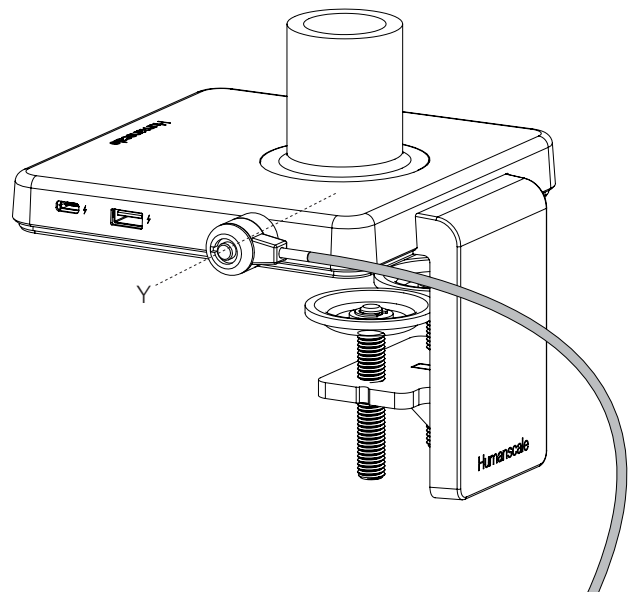
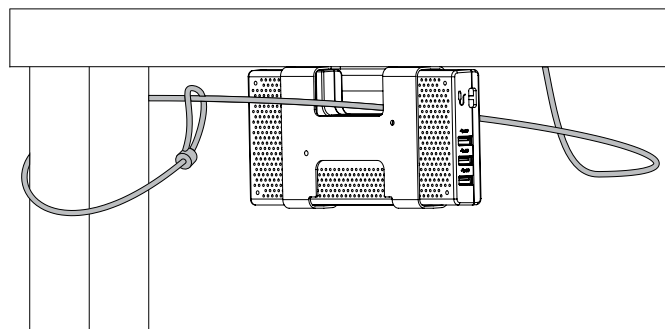
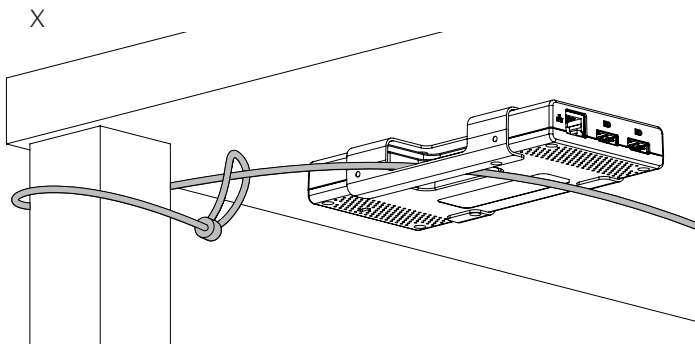
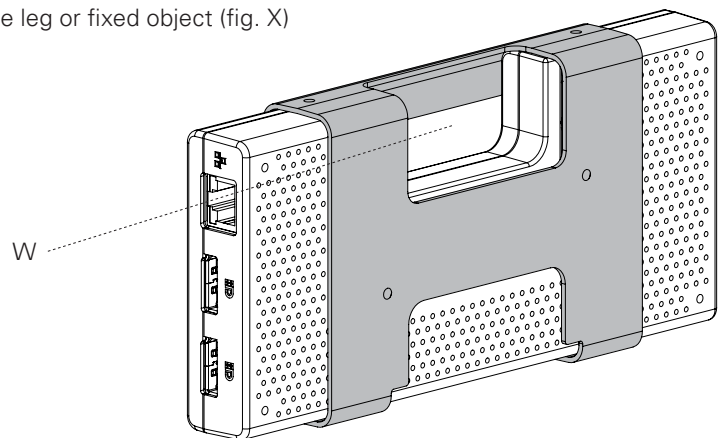

# RECOMMENDED SYSTEM REQUIREMENTS

## Minimum Requirements for Office, Productivity, Web

Processor: Intel Core i3 2+GHz / Intel Core M / AMD Trinity or better

Memory: 4GB

Video Card: Intel HD 4000, ATI Radeon HD7xxx, NVidia GeForce 5xxM or better, with drivers released specifically for the Windows version.

USB: USB 2.0 but USB 3.0 recommended

## Minimum Requirements for Full-Screen Video Playback

Processor: Intel SkyLake i3 or Intel Core i7 2+GHz / AMD Richland A10-575x / AMD

Kaveri A10-7400P or better

Memory: 8GB

Video Card: Intel HD 4000, ATI Radeon HD 8650, NVidia GeForce 7xxM or better, with drivers released specifically for the Windows version.

USB: USB 3.0

Disk: 7200RPM or SSD

If playing UHD content (4K), the system must be capable of decoding the 4K video in the GPU.

# ELECTRICAL SPECIFICATIONS

<b>Base Hub - 60W</b>	<b>USB ports</b>	USB-C full feature with PD charging 60W Support PD2.0 version 1.2 (BC protocol devices not supported)			
	<b>USB ports</b>	2x USB-A 3.1 Gen1 with charging (5V, 2.4A)			
	<b>USB Ports – charging only, no data communication</b>	USB-C (5V, 3.0A max) USB-A (5V, 2.4A max)			
	<b>Microphone/Headphone</b>	3.5mm combo jack			
<b>Base Hub - 100W</b>	<b>USB ports</b>	USB-C full feature with PD charging 100W Support PD2.0 version 1.2 (BC protocol devices not supported)			
	<b>USB ports</b>	2x USB-A 3.1 Gen1 with charging (5V, 2.4A)			
	<b>USB Ports – charging only, no data communication</b>	USB-C (5V, 3.0A max) USB-A (5V, 2.4A max)			
	<b>Microphone/Headphone</b>	3.5mm combo jack			
<b>Dock</b>	<b>Without HDCP enabled</b>	<b>5k</b> 5120x2880 p60	<b>4k</b> 3840x2160 p60 4096x2160 p60	<b>2k</b> 2560x1600 p60 2560x1440 p60	<b>1k</b> FHD
	<b>Video 1 output</b> DP++ (Dual mode DP1.2)	Supports (1) 5K monitor	✓	✓	✓
	<b>Video 2 output</b> DP++ (Dual mode DP1.2)		✓	✓	✓
	<b>Network</b>	Gigabit Ethernet Transfer rate 10Mbit/100Mbit/1Gbit			
	<b>USB Ports</b>	2x USB-A 3.1 Gen1 (5V, 0.9A) 1x USB-A 3.1 Gen1 with charging (5V, 2.4A)			
<b>Operating System</b>	Windows 7/7Pro (32bit/64bit), Windows 8.1/8.1Pro (32bit/64bit), Windows 10 (32bit/64bit), Apple OS X Version 10.8.3 and above (Mountain Lion v10.8, Mavericks v10.9, Yosemite v10.10, El Capitan v10.11(ver2.5), Sierra mac OS10.12(ver2.6) )				

# ELECTRICAL SPECIFICATIONS

<b>Environmental</b>	<b>Temperature - Operating</b>	0°C to 40°C
	<b>Temperature - non-Operating</b>	-20°C to 60°C
	<b>Relative Humidity - Operating</b>	10% to 80% (non-condensing 5°C to 35°C)
	<b>Relative Humidity - non-Operating</b>	5% to 90% (non-condensing -20°C to 60°C)
	<b>Altitude - Operating</b>	Sea level to 5000m
	Designed to meet RoHS and WEEE directives	
<b>Dimension</b>	<b>Hub</b>	150mm (w) x 150mm (d) x 22.5mm (h)
	<b>Dock</b>	191mm (w) x 90mm (d) x 23mm (h)
<b>Weight</b>	2.1 kg (dock and hub)	
<b>AC Power Adapter</b> (for 60W Hub)	<b>Input Voltage</b>	90 – 264V (47-63Hz)
	<b>Output Voltage</b>	20V (+/- 5%), 7.5A, 150W
	<b>Efficiency</b>	Meets US DoE VI
<b>AC Power Adapter</b> (for 100W Hub)	<b>Input Voltage</b>	90 – 264V (47-63Hz)
	<b>Output Voltage</b>	20V (+/- 5%), 9A, 180W
	<b>Efficiency</b>	Meets US DoE VI
<b>Accessories Included</b>	1x USB-C full feature cable - 1.0m in long w/. a USB-C to USB-A adapter attached	



## FCC Notice

M/Connect2 Models MC2-AXY and MC2-BXY (where X and Y can be alphanumeric or blank)

This device complies with part 15 of the FCC Rules. Operation is subject to the following two conditions: (1) This device may not cause harmful interference, and (2) this device must accept any interference received, including interference that may cause undesired operation.

Note: This equipment has been tested and found to comply with the limits for a Class B digital device, pursuant to part 15 of the FCC Rules. These limits are designed to provide reasonable protection against harmful interference in a residential installation. This equipment generates, uses and can radiate radio frequency energy and, if not installed and used in accordance with the instructions, may cause harmful interference to radio communications. However, there is no guarantee that interference will not occur in a particular installation. If this equipment does cause harmful interference to radio or television reception, which can be determined by turning the equipment off and on, the user is encouraged to try to correct the interference by one or more of the following measures:

- Reorient or relocate the receiving antenna.
- Increase the separation between the equipment and receiver.
- Connect the equipment into an outlet on a circuit different from that to which the receiver is connected.
- Consult the dealer or an experienced radio/TV technician for help.

The FCC requires the user be cautioned that any changes or modifications made to this device that are not expressly approved by Humanscale may void the user's authority to operate the equipment.

Connections to this device must be made with shielded cables in order to maintain compliance with the Class B limits in the FCC Rules and Regulations.

Humanscale

1114 Avenue of the Americas

New York, NY 10036

+1 (800) 400-0625

## Innovation, Science and Economic Development Canada ICES-003 Compliance Notice:

CAN ICES-3 (B)/NMB-3(B)