

#### For Troubleshooting

- Contact your local customer service department (see below) or go to [support.displaylink.com](http://support.displaylink.com).
- The complete User Guide can be downloaded from [www.humanscale.com/mconnect2](http://www.humanscale.com/mconnect2).
- Make sure to download the correct drivers before you turn M/Connect on at [displaylink.com/downloads](http://displaylink.com/downloads).
- Do not use this AC Adapter for other purposes than for its original intention for usage with M/Connect 2

#### En cas de problème

- Veuillez contacter le service client de votre région (voir ci-dessous) ou allez sur [support.displaylink.com](http://support.displaylink.com).
- Vous pouvez télécharger le guide d'utilisation complet à partir du lien suivant: [www.humanscale.com/mconnect2](http://www.humanscale.com/mconnect2).
- Assurez-vous de télécharger les pilotes appropriés sur [displaylink.com/downloads](http://displaylink.com/downloads) avant d'allumer le M/Connect.
- Ne pas utiliser cet adaptateur CA à d'autres fins que celles initialement prévues avec M/Connect 2.

#### Para solución de problemas

- Póngase en contacto con su departamento local de atención al cliente (véase más adelante) o visite [support.displaylink.com](http://support.displaylink.com).
- La Guía del usuario completa puede descargarse desde [www.humanscale.com/mconnect2](http://www.humanscale.com/mconnect2).
- Antes de encender M/Connect, asegúrese de descargar los controladores correctos desde [displaylink.com/downloads](http://displaylink.com/downloads).
- No utilice este adaptador de CA para otros fines distintos de su uso previsto con M/Connect 2.

#### Risoluzione dei problemi

- Contatta il servizio di assistenza clienti (vedi sotto) o vai su [support.displaylink.com](http://support.displaylink.com).
- Scarica il manuale d'uso completo [www.humanscale.com/mconnect2](http://www.humanscale.com/mconnect2).
- Prima di accendere M/Connect, scarica i driver corretti [displaylink.com/downloads](http://displaylink.com/downloads).
- Non utilizzate questo adattatore CA per usi diversi da quello previsto con M/Connect 2.

#### Fehlersuche

- Kontaktieren Sie den Humanscale Kundendienst vor Ort (siehe unten) oder gehen Sie zu [support.displaylink.com](http://support.displaylink.com).
- Die vollständige Bedienungsanleitung können Sie unter [www.humanscale.com/mconnect2](http://www.humanscale.com/mconnect2) herunterladen.
- Überprüfen Sie, ob alle Treiber für M/Connect korrekt heruntergeladen wurden, welche Sie unter [displaylink.com/downloads](http://displaylink.com/downloads) finden.
- Nutzen Sie den mitgelieferten AC Adapter ausschließlich für den beabsichtigten Zweck der Verwendung mit M/Connect 2

#### Problemen oplossen

- Neem contact op met de lokale klantenservice (zie hieronder) of ga naar [support.displaylink.com](http://support.displaylink.com).
- De volledige gebruiksaanwijzing is te downloaden op [www.humanscale.com/mconnect2](http://www.humanscale.com/mconnect2).
- Voordat M/Connect wordt ingeschakeld, dienen de juiste drivers te worden gedownload op [displaylink.com/downloads](http://displaylink.com/downloads).
- Gebruik de meegeleverde netspanningsadapter uitsluitend voor M/Connect 2 en niet voor andere doeleinden.

#### Em caso de problemas

- Entrar em contato com o serviço de atendimento ao cliente local (veja abaixo) ou busque por assistência na página [www.support.displaylink.com](http://www.support.displaylink.com).
- O manual de instruções completo pode ser baixado em [www.humanscale.com/mconnect2](http://www.humanscale.com/mconnect2).
- Assegure-se de fazer o download correto dos drivers antes de ligar o M/Connect na página [www.displaylink.com/downloads](http://www.displaylink.com/downloads).
- Não usar o adaptador AC para outros fins além de sua utilização original junto ao M/Connect 2

#### 技术支持

- 联系当地客户服务部门(见下文)或访问 [support.displaylink.com](http://support.displaylink.com)。
- 请点击链接下载完整的用户指南 [www.humanscale.com/mconnect2](http://www.humanscale.com/mconnect2)。
- 使用 M/Connect 之前, 请确保下载正确的驱动程序。下载请至 [displaylink.com/downloads](http://displaylink.com/downloads)。
- 请不要将此交流适配器用于M/Connect 2 以外的用途

#### トラブルシューティング

- 最寄りのカスタマーサービス部門にご連絡いただく(下記参照)、[support.displaylink.com](http://support.displaylink.com)へアクセスしてください。
- 詳しいユーザーガイドは [www.humanscale.com/mconnect2](http://www.humanscale.com/mconnect2) からダウンロードできます。
- [displaylink.com/downloads](http://displaylink.com/downloads) へアクセスして、ドライバをインストールしてからM/Connectのスイッチを入れてください。
- このACアダプターをM/Connect2に接続する本来の用途以外には使用しないでください。

#### 문제 해결

- 현지 고객 서비스 부서(아래 참조)에 문의하거나 [support.displaylink.com](http://support.displaylink.com)으로 문의 하십시오.
- [www.humanscale.com/mconnect2](http://www.humanscale.com/mconnect2)에서 전체 사용자 가이드를 다운로드할 수 있습니다.
- M/Connect를 켜기 전에 [displaylink.com/downloads](http://displaylink.com/downloads)에서 올바른 드라이버를 다운로드해야 합니다.
- 이 AC 어댑터를 M/Connect 2와 함께 사용하기 위한 원래 용도 이외의 용도로 사용하지 마십시오.

#### לפתרון תקלות

- נא ליצור קשר עם מחלקת שירות הלקוחות או מקומית (ראה מטה) או לפנות לאתר [support.displaylink.com](http://support.displaylink.com).
- ניתן להוריד את המדריך למשתמש המלא מהכתובת [www.humanscale.com/mconnect2](http://www.humanscale.com/mconnect2).
- נא לוודא שהורדת את מנהלי ההתקן הנוכחים מהכתובת [displaylink.com/downloads](http://displaylink.com/downloads) לפני הדלקת M/Connect.
- אין להישתמש במתאם AC עבור שום מטרה למעט השימוש המקורי עם M/Connect 2

North America: +1 800-400-0625

Europe: +353 (0)1 858 0910

Asia Pacific: +852 2581 0570

HS/MCOS0519

# M/Connect<sup>TM</sup> 2

## QUICK START GUIDE

## GUIDE D'INSTALLATION RAPIDE DE

## GUÍA DE INSTALACIÓN RÁPIDA DE

## GUIDA DI INSTALLAZIONE

## SCHNELLINSTALLATION

## BEKNOPTE INSTALLATIEHANDLEIDING

## MANUAL RÁPIDO

## 快速安装指南

## クイックセットアップガイド

## 빠른 시작 가이드

## מדריך התחלה מהירה

Humanscale®

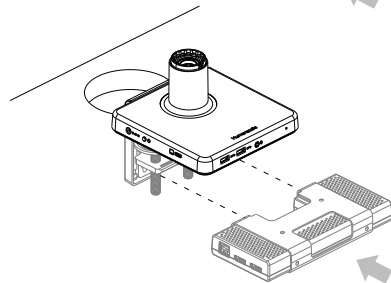
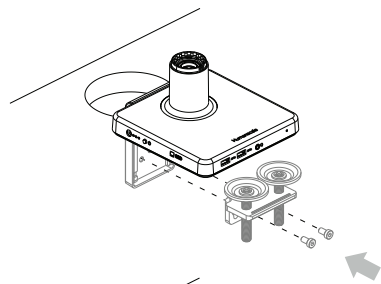
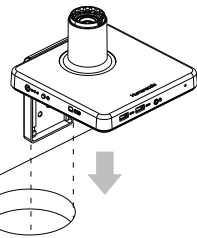
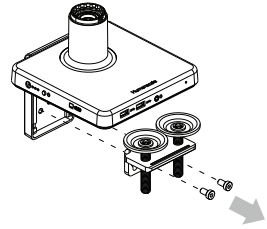
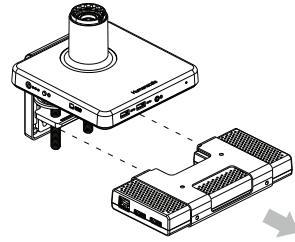
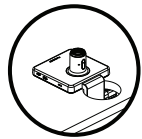
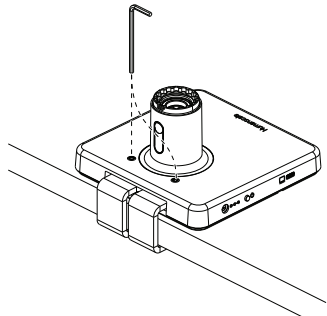
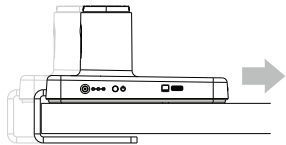
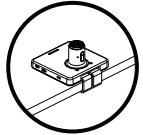
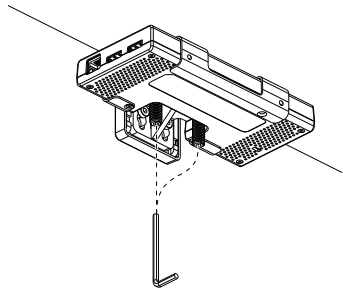
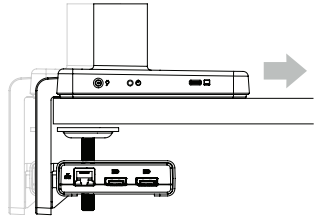
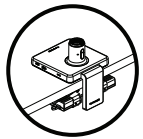

M2.1  
M8.1  
M10

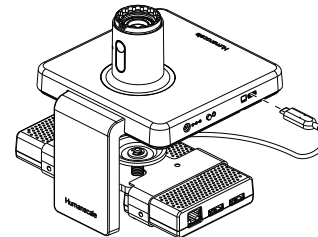
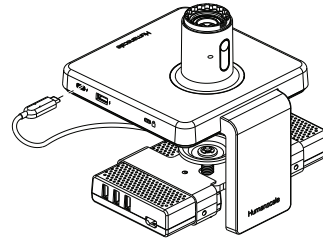
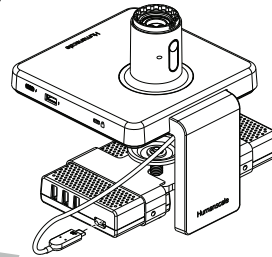
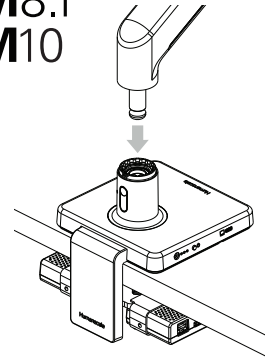

M/FLEX

