

Forum.

aspect 

Forum.
Designed for you
and your thoughts.





Built for both individual focus and collaborative conversation, Forum is a collection of sofas and seating booths that adapt to the evolving needs of the workplace. Forum sofas placed facing one another form small, intimate meeting areas. When isolated, they provide a quiet space to think – a place of refuge in a busy office.

Clean lines merge with soft, curved surfaces to create a timeless and elegant sofa suited to any commercial interior. Carefully crafted to provide optimal support, Forum's design ensures that individuals can sit comfortably for hours.

Crafted around the user experience, Forum provides ultimate support and seamlessly integrates into workplace environments. Carefully selected materials ensure low environmental impact, strength and durability.



**Designed
and made in
New Zealand –
100%.**

Forum is designed and manufactured in New Zealand by Aspect's in-house team. Our commitment to using sustainably sourced materials ensures the highest quality, consistency and timely delivery of our products.

As furniture designers, our user-centric approach places people at the heart of every decision we make. Based on this philosophy, we designed Forum as a shelter for people to collaborate, converse and focus.





The Forum range starts with a single, two or three seater.

Selection.

Featuring a variety of low or high back sofas and booths with connecting media panel. Integrated tables and visual displays can be added for further functionality.

By combining comfort, flexibility and adjustability, Forum ensures that your workplace remains agile and resilient to evolving work styles and user needs.

Design features.



Comfort.

Sprung seats and generous foam offer plenty of comfort. Made to last with a structural steel under-frame, solid timber or steel legs and a timber sub-frame.

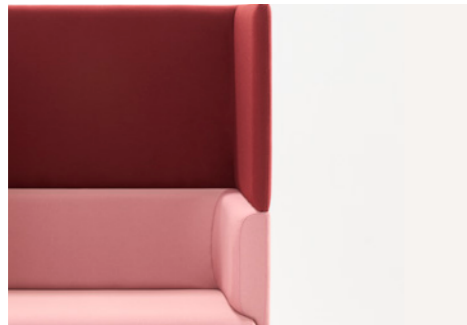

Sound absorbing.

Forum high backs provide visual and acoustic privacy, shielding outside noise and distraction in busy open-plan environments.

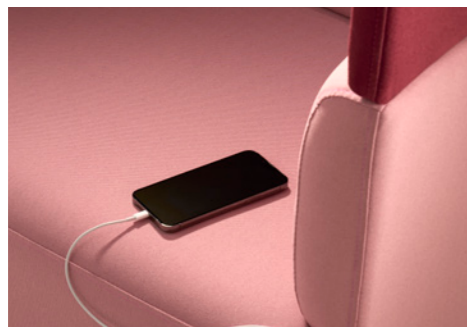

Connectivity.

Forum accommodates integrated device charging points and surface mounted monitors.



Forum collection.

Forum sofa.

Single seater.

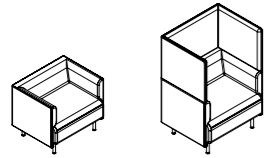

Low back. High back.

Two seater.

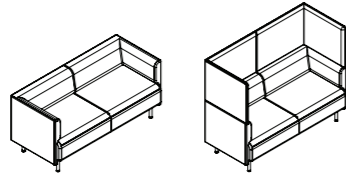

Low back. High back.

Three seater.

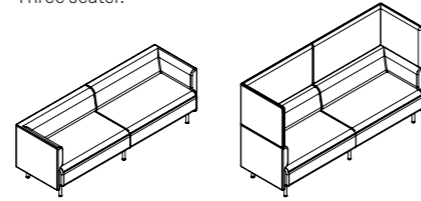

Low back. High back.

Forum booth.

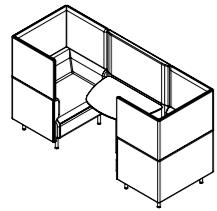

Two seater.

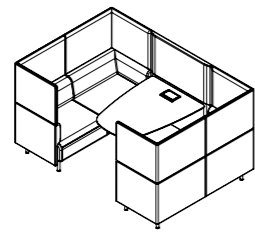

Four seater.

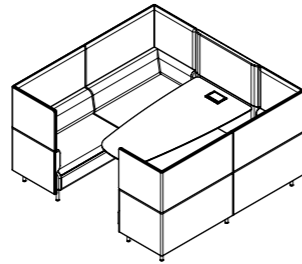

Six seater.

Forum module seat height & foot detail.

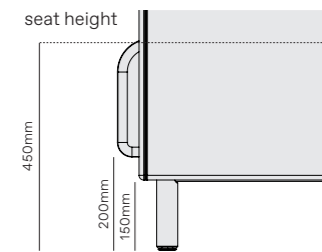

Timber legs.

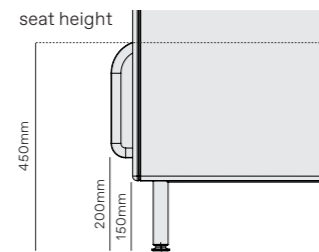

Steel legs.



Sofa specifications.

Single seater.

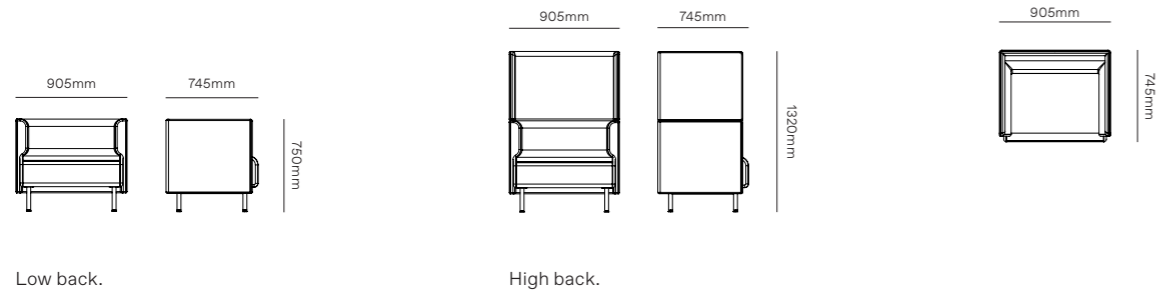

Low back.

High back.

Two seater.

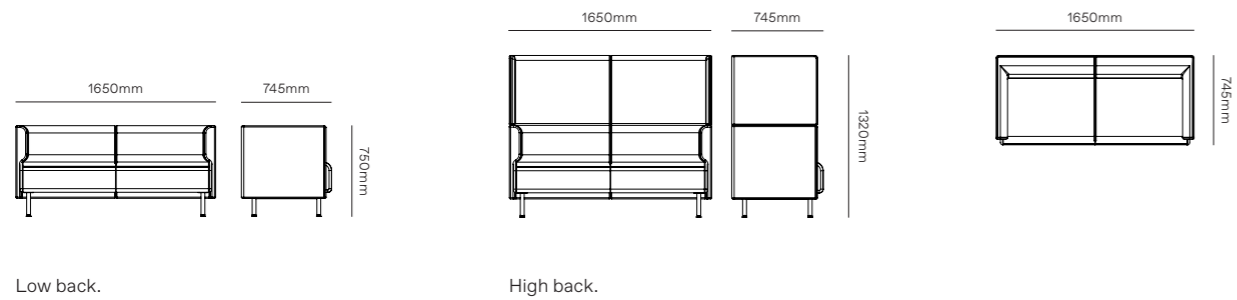

Low back.

High back.

Three seater.

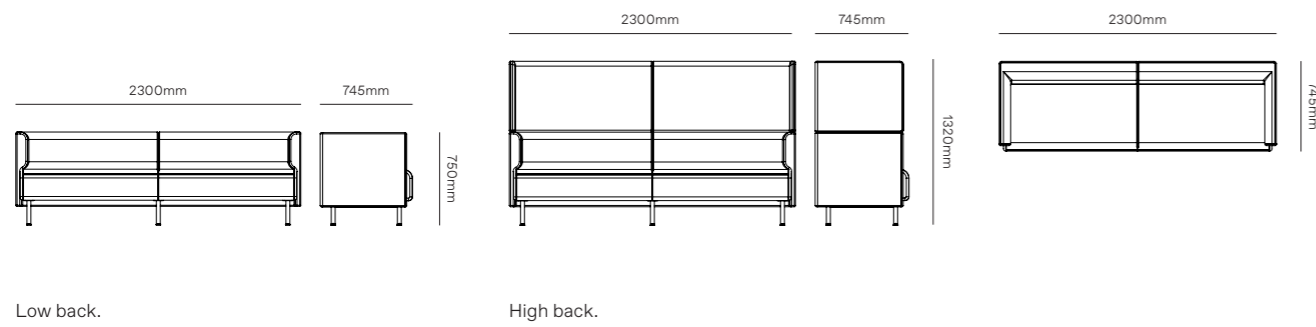

Low back.

High back.

Available with either solid timber or steel legs.

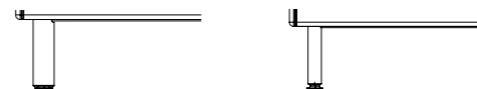

Forum booth.

Featuring power and integrated work surfaces, Forum booths can be easily accessorised with displays to provide additional functionality.

The Forum booth is available in 2, 4 and 6-seater configurations to suit your space and needs.

The Forum booth is a place to meet, present and collaborate.



Booth specifications.

Two seater.

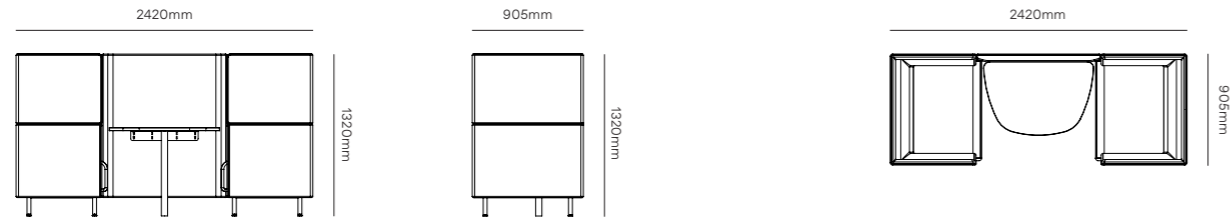

Four seater.

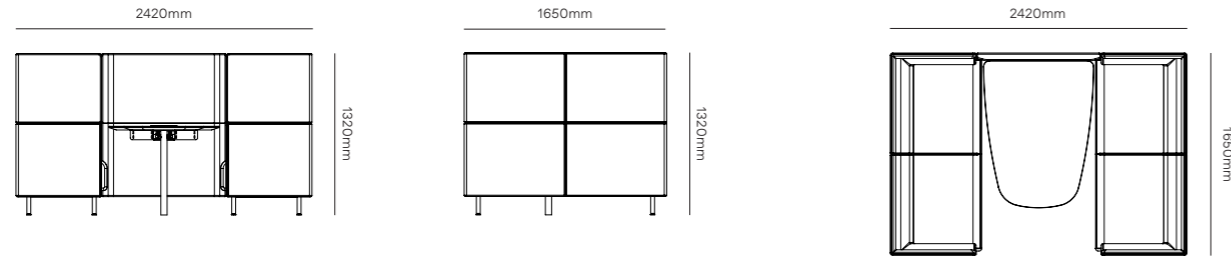

Six seater.

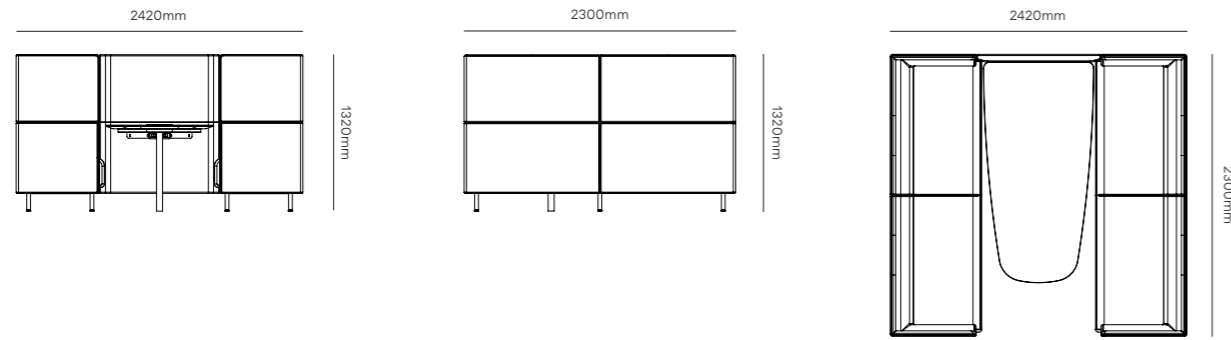

Available with either solid timber or steel legs.

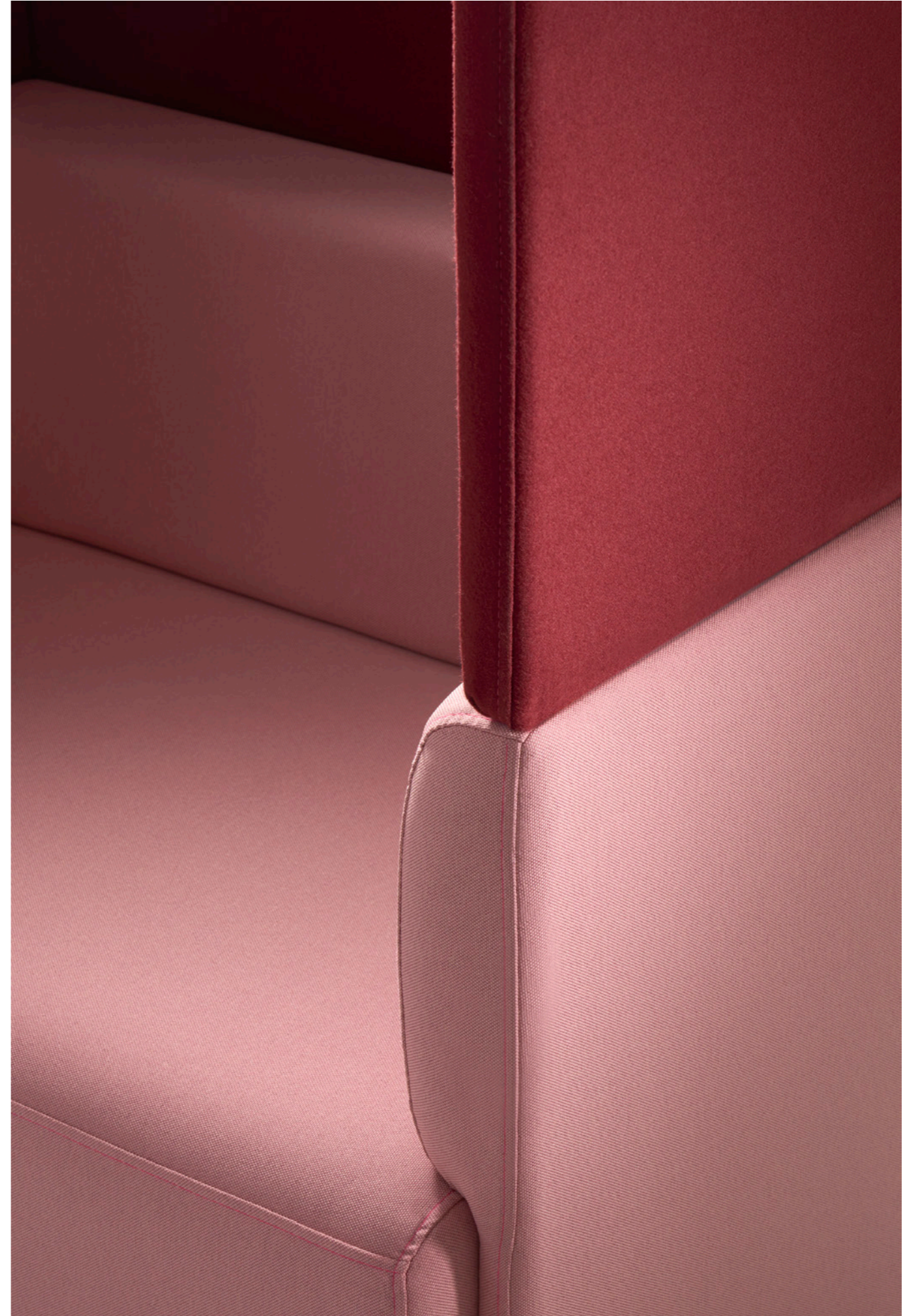
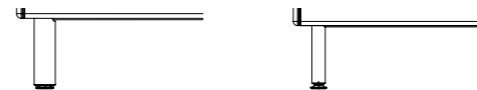

Product details.

An Aspect product. Designed by Aspect.

Made in New Zealand.

Finishes	Choose from fabric, leather or vinyl Upholstered in New Zealand
Variations	Sofa modules, booth modules Standard Ash Timber or powdercoated Mannex Black steel legs
Warranty	10-Year warranty for normal commercial use Fabric as per manufacturers warranty
Lead Time	4–8 weeks



We believe that high-performing spaces enable high-performing people.

We place a person's comfort and ease-of-use at the heart of every product and system we create. Aspect designers and workplace specialists help you create a complete office furniture solution that will inspire and support people in their work every day.

Back in 1982, from a small factory in Auckland, Aspect founder and CEO Richard Simmons made his very first furniture prototypes. Driven by a passion for craft and beautiful engineering, he steadily grew the business and is joined today by his three sons and an expert team of designers, engineers and workplace specialists across New Zealand and Australia. Today, Aspect makes collections at the leading edge of international product design, technology, and workplace best practice.

Our focus on crafted, fully resolved commercial furniture means Aspect collections are trusted by some of the largest public and private organisations around Australasia. With over 40 years' experience designing and manufacturing collections for the modern workplace, our office furniture has a reputation for being robust, ergonomic, and comfortable throughout the working day.

We make over 70 per cent of our product range in New Zealand and Australia for true control over design, quality, customisation, and lead times. You receive products quickly and reliably from a quality-assured environment. In addition to speed and

flexibility, local manufacturing also creates a smaller environmental footprint.

Our team of product designers and workplace specialists help you define and select a furniture solution to meet your workplace aspirations and project budget using durable and environmentally sound products.

Direct access to our furniture designers means greater flexibility and control over your solution, as we work from our collections, adapt existing products, or design new components.

Aspect Furniture operates ethical and sustainable business practices. We have certification from Good Environmental Choice Australia (GECA) and Environmental Choice New Zealand (ECNZ), and our products are aligned to the Green Star rating tool. Independent certifiers regularly audit our premises under the ISO 9001 and ISO 14001 quality and environmental management systems. Similarly, the health and safety of our employees is vital to our success, so we are certified to the globally recognised AS/NZS 4801 and ISO 45001 occupational health and safety standards.



Furniture, Fittings and Flooring
Licence Number
3210076



New Zealand

0800 323 220
info@aspectfurniture.com

Australia

1800 696 334
infoau@aspectfurniture.com

aspectfurniture.com

Showrooms

Auckland
Wellington
Christchurch
Sydney
Melbourne
Canberra

